

REV.	ECO/DDC	DESCRIPTION	DATE	DRAFT	CHECK	APV'D
A	----	RELEASED.	02-12-21	V.J.C.	T.D.N.	V.J.C.

DIMENSIONS IN INCHES [MM]		
HEIGHT-NOMINAL	HEIGHT-MINIMUM	HEIGHT-MAXIMUM
26.0 [660.4]	24.0 [609.6]	28.0 [711.2]
30.0 [762.0]	28.0 [711.2]	32.0 [812.8]
34.0 [863.6]	32.0 [812.8]	36.0 [914.4]
38.0 [965.2]	36.0 [914.4]	40.0 [1016.0]
42.0 [1066.8]	40.0 [1016.0]	44.0 [1117.6]

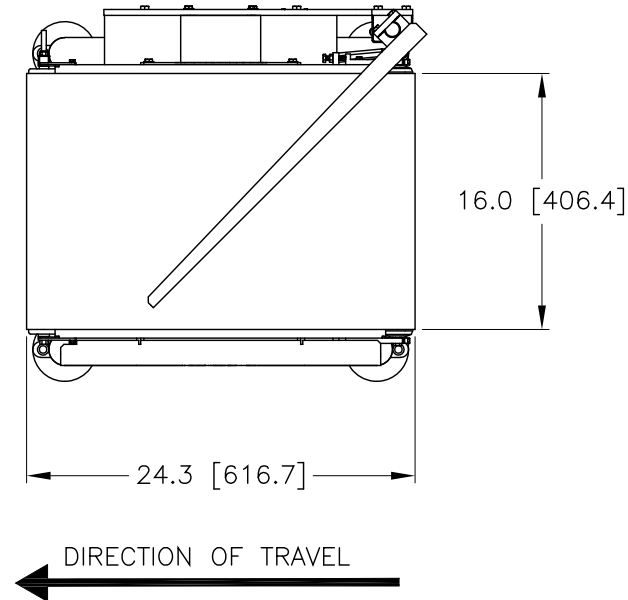

Customer Provided Variables

Package Information

Description:				
	Length (in)	Width (in)	Weight (lb.)	Rate (ppm)
Largest Pkg				
Smallest Pkg				

Material Handling

	Infeed Speed (fpm)	Controlled Spacing (Y/N)	Minimum Package Pitch (in)	Package Direction (L-R, R-L)
Largest Pkg				
Smallest Pkg				

Pitch to be stated as center to center spacing of one package to the next

Belt Type (check one): Black(PVC) White(FDA)

Roller (check one): Galv (IP54) SS (IP66)

Construction (check one): Painted Stainless

Performance

Maximum Rcmd. Weight	Maximum Speed	Enviro. Rating	Voltage / Current	Air (Reject Only)
40 lbs	120FPM		120 VAC / 5 AMP	80 PSI / 4 CFM

Customer Approval Signature _____
 Print Name _____
 Date _____

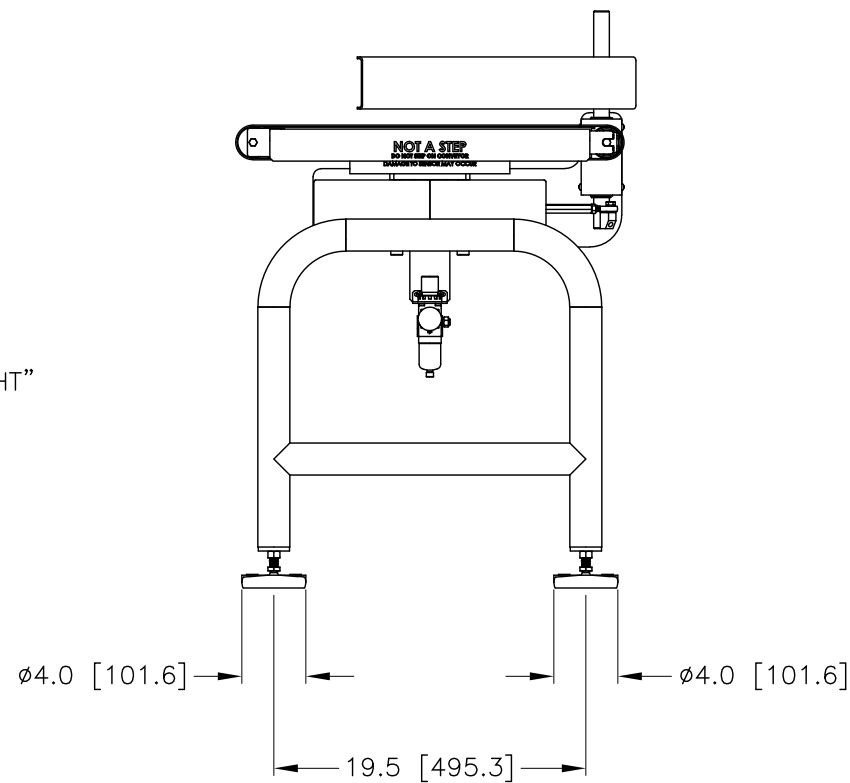
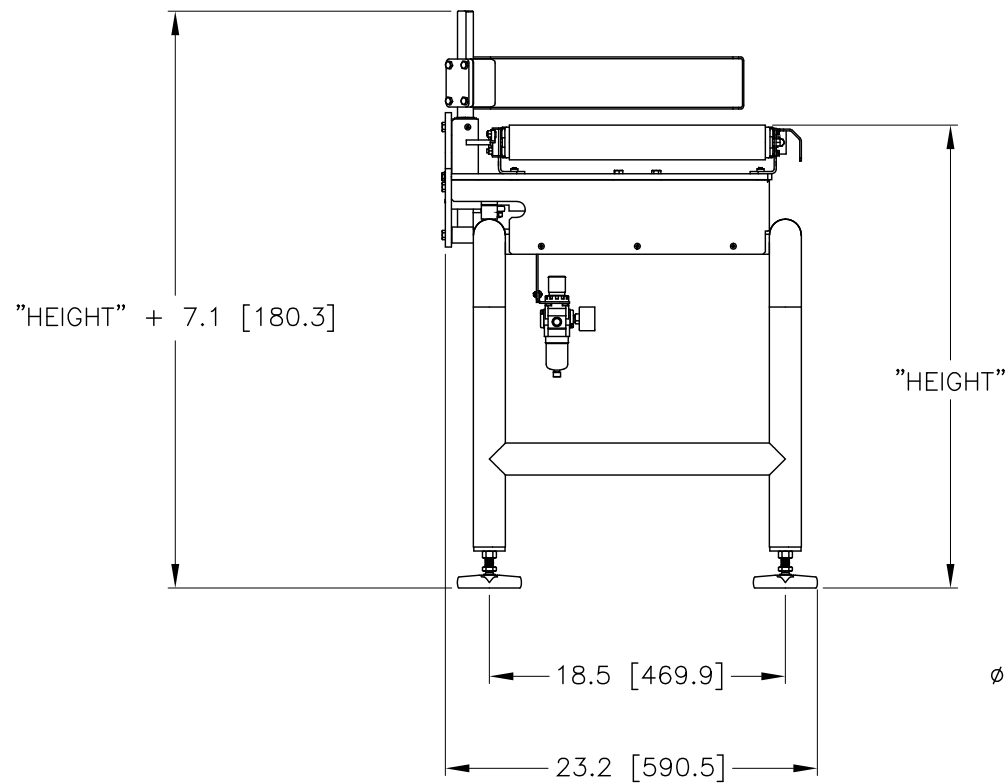

NOTES: UNLESS OTHERWISE SPECIFIED

PROPRIETARY NOTICE
 ALL DATA AND INFORMATION CONTAINED IN OR DISCLOSED BY THIS DOCUMENT IS CONFIDENTIAL AND PROPRIETARY INFORMATION OF HARDY PROCESS SOLUTIONS INC. AND ALL RIGHTS THEREIN ARE EXPRESSLY RESERVED. BY ACCEPTING THIS MATERIAL THE RECIPIENT AGREES THAT THIS MATERIAL AND THE INFORMATION CONTAINED THEREIN IS HELD IN CONFIDENCE AND IN TRUST AND SHALL NOT BE USED, COPIED, REPRODUCED IN WHOLE OR IN PART, NOR ITS CONTENTS REVEALED IN ANY MANNER TO OTHERS, EXCEPT TO MEET THE SPECIFIC PURPOSE FOR WHICH IT WAS DELIVERED.

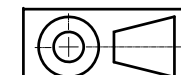

0588-0202		LAYOUT DRAWING, HPS-ORC, 16"x24", RIGHT TO LEFT DIRECTION										
ITEM	QTY	PART NUMBER	DESCRIPTION	COMMENTS								
PARTS LIST												
UNLESS OTHERWISE SPECIFIED DIMENSIONS ARE IN INCHES TOLERANCES ARE:		CONTRACT NO.										
FRACTIONS: N/A		<table border="1"> <tr> <th colspan="2">APPROVALS</th> </tr> <tr> <td>DRAWN V. CHULA</td> <td>DATE 02-03-21</td> </tr> <tr> <td>CHECKED T. NORMAN</td> <td>DATE 02-12-21</td> </tr> <tr> <td>APPROVED V. CHULA</td> <td>DATE 02-12-21</td> </tr> </table>			APPROVALS		DRAWN V. CHULA	DATE 02-03-21	CHECKED T. NORMAN	DATE 02-12-21	APPROVED V. CHULA	DATE 02-12-21
APPROVALS												
DRAWN V. CHULA	DATE 02-03-21											
CHECKED T. NORMAN	DATE 02-12-21											
APPROVED V. CHULA	DATE 02-12-21											
DECIMALS: .XX = ±.03 .XXX = ±.010		TITLE										
ANGLES: ±0°, 30°		LAYOUT DRAWING, HPS-ORC, 16"x24", RIGHT TO LEFT DIR										
MATERIAL		SIZE FSCM DRAWING NO. REV.										
FINISH		D 21316 0588-0202 A										
DO NOT SCALE DRAWING		FILE NAME: 0588-0202A1.DWG SCALE: NONE SHEET 1 OF 1										

